

COOLING THROUGH WATER CONDUCTIVITY

// 1.
A FRAME IS CONSTRUCTED

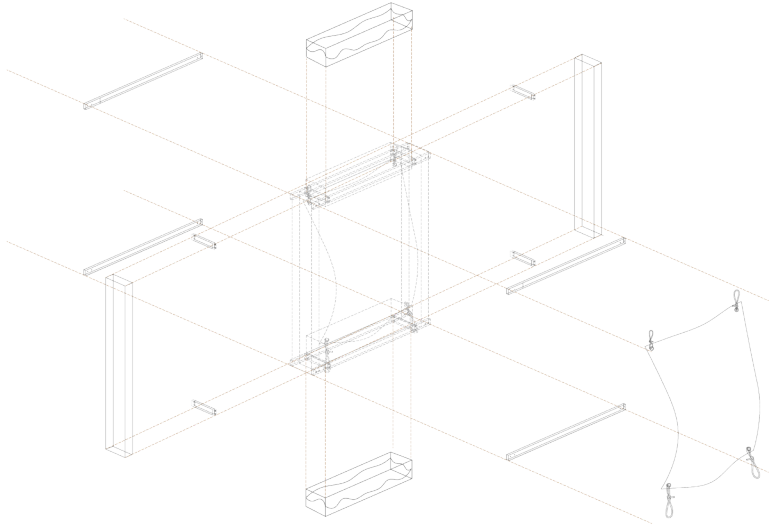

// 2.
A WATER TANK IS PLACED AS A LINTEL

// 3.
THE FABRIC IS STRECHED TIGHT ON A SLIGHT SLOPE ACROSS THE FRAME

// 4.
THE TANK IS PERFORATED WITH SMALL OPENINGS

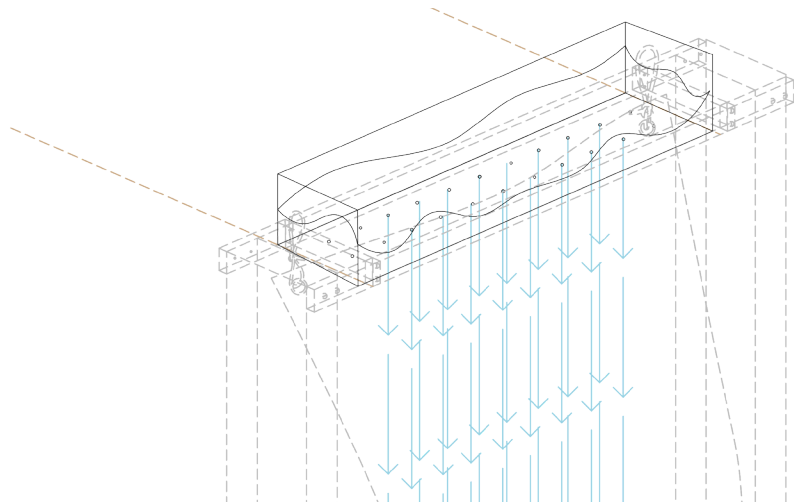

// 5.
THE WATER DROPS GRADUALLY WET THE FABRIC

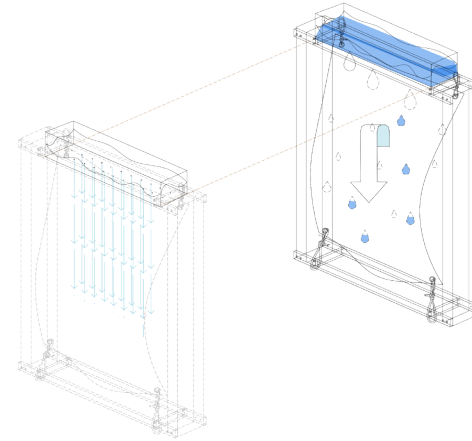

// 6.
THE OCEAN BREEZE TRANSMITTS THERMAL COMFORT

